



EASY TOUCH 2

User friendly and totally programmable 7" ET2 USB Connection. Online platform free of charge for programming, telemetry, data analysis...thanks to the IoT Videos on display (ads, instructions, etc.)
37 languages



OUTSTANDING FEATURES

Reversing drum action as standard
Stainless steel drum as standard
Frequency inverter as standard



EFFICIENCY

CARE DRY - Intelligent humidity control. With new drum inlet temperature control.
AIR RE-CYCLE - Efficient air recirculation system
INSULATED PANELS - Complete air-flow circuit
Double door glass
OPTIMAL FLOW - New optimized system of mixed airflow
Big fluff filter



VERSATILITY

Make to order - customisation
WET CLEANING



CONNECTIVITY

Standard Danube Online IoT communication
Remote technical service
Management of laundries:



ERGONOMICS

Drawer as fluff filter, stainless steel mesh
Biggest door diameters
Opening sense of door adjustable on site



MAINTENANCE

Hinged control panel: easy and ergonomic access
Technical menu: statistics for technicians and maintenance with external console (with console option)



OTHERS

Grey skinplate outer casing, stainless steel look
Transmission by direct drive
SPRINKLER - Integrated Fire Extinguishing System
SOFT DRY - new drum with stamped holes
COOL DOWN - anti-wrinkle at the end of the cycle
Electric, gas and steam heating
CE approved



OPTIONS

- Opposite door opening
- Tropicalized model
- Dosing/spraying system
- Back panel external air + filter
- Fluff filter with grid 0,6mm (standard is 0,3mm)
- Fluff filter with grid 1,2mm (standard is 0,3mm)
- Stainless steel front and side panels
- Front panel in stainless steel
- Steam battery in stainless steel
- Low pressure steam battery
- Ship voltage for electric models: 440V III 50/60 Hz No neutral
- Other voltages available
- Maritime wooden packing

TECHNICAL DATA	UNIT.	DD-28-GOLD ET2		DD-35-GOLD ET2	
CAPACITY					
Capacity 1/18 // Capacity 1/20	Kg	30,5 // 27,5		36,6 // 27,5	
Hourly Output (electr. // gas)	Kg/h	51,6 // 61,1		63,9 // 73,3	
Evaporation capacity (electr. // gas)	l/h	26,8 // 31,8		31,5 // 34,7	
DRUM					
Ø Drum	mm	947		947	
Ø Door	mm	802		802	
Door center height	mm	1040		1040	
Load hole bottom height	mm	640		640	
Drum length	mm	780		936	
Drum volume	l	549		659	
POWER					
Drum motor power	kW	0,55		0,55	
Fan motor power	kW	0,75		0,75	
Electric heating power	kW	30		36	
Total electric power (elec.model)	kW	31,15		37,35	
Gas heating power	kW	41		41	
Instant propane gas consumption (G31)	kg/h	3,51		3,51	
Instant natural gas consumption (G20)	m3/h	4,34		4,34	
Total electric power (gas model)	kW	1,35		1,35	
Steam heating power	kW	50,10		50,10	
Total electric power (steam model)	kW	1,35		1,35	
CONNECTIONS					
		ELECTRICAL		GAS/STEAM	
Tension 230V - I + N + T	Nº x mm2 / A	-		3 x 1,5 / 20A	
Tension 230V - III + T	Nº x mm2 / A	4 x 35 / 100A		3 x 1,5 / 20A	
Tension 400V - III + N + T	Nº x mm2 / A	5 x 16 / 63A		3 x 1,5 / 20A	
Ø Gas inlet	BSP	1/2"		1/2"	
DIMENSIONS / PACKING DIMENSIONS					
Net width / Gross width	mm	985 / 1065		985 / 1065	
Net Depth / Gross Depth	mm	1054 / 1154		1210 / 1310	
Net Height / Gross Height	mm	1975 / 2080		1975 / 2080	
Net weight / Gross weight	Kg	230 / 260		260 / 285	
OTHERS					
Max airflow	m3/h	1500		1500	
Ø Fume exhaust	mm	200		200	
Sound level	dB	65		65	

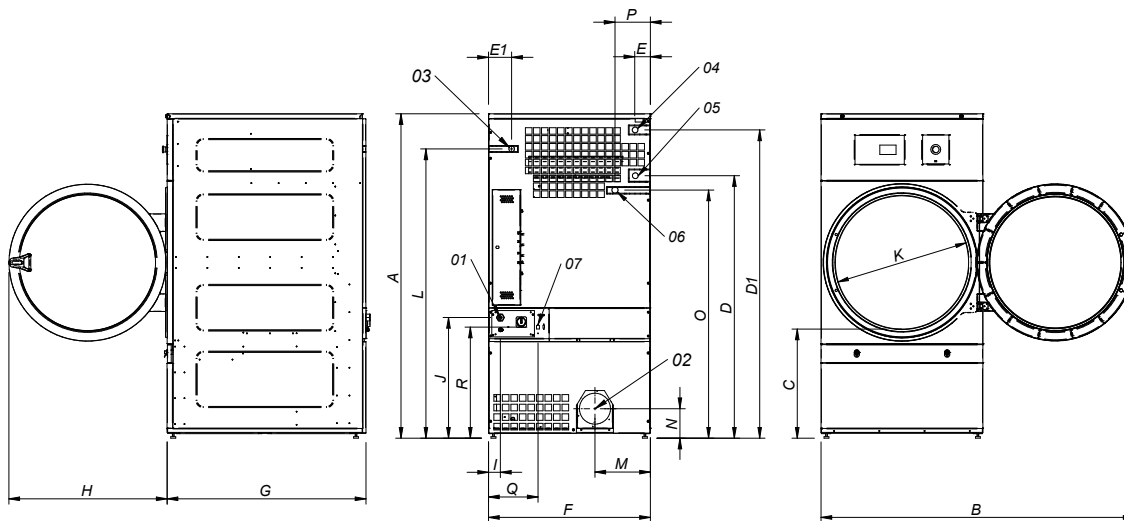

- 01 POWER SUPPLY
- 02 FUMES OUTPUT Ø200
- 03 GAS INLET 1/2"
- 04 STEAM INLET 1"
- 05 CONDENSATE OUTLET 1"
- 06 SPRINKLER VALVE 3/4"
- 07 ETHERNET CONNECTION

	A	B	C	D	D1	E	E1	F	G	H	I	J	K	L	M	N	O	P	Q	R
DD-28	1975*	1910	660	1590	1875	102	130	985	1054	970	70	730	802	1760	337	178	1510	215	301	676
DD-35	1975*	1910	660	1590	1875	102	130	985	1210	970	70	730	802	1760	337	178	1510	215	301	676

* Measurement with legs mounted (30mm)

