

## ORACRS

HIGH SPEED OVEN - ALL IN ONE. COMBI WAVE / HIGH SPEED OVEN - BOOSTED VERSION • TOTAL PLUG & PLAY - DESIGNED FOR USE ANYWHERE



## Features



### HIGH SPEED OVEN

An operating mode that simultaneously uses convection, microwave and impingement modes, with temperatures from 100°C to 300°C.



### FAST COOKING SYSTEM

Rely on Lainox's know-how by using the automatic, tried-and-tested recipes for high-speed cooking in High Speed Oven mode.



### COMBI WAVE

In Combi Wave mode, Oracle can be used as a convection oven with temperatures from 30°C to 300°C, as a microwave oven with power up to 2000 W or with a combination of the two cooking methods to achieve results that always exceed expectations.



### MICROWAVE COOKING SYSTEM

Rely on Lainox's know-how by using the automatic, tried-and-tested recipes for cooking in Combi Wave mode.



### CONNECTED

Oracle connects free-of-charge to Lainox's Nabook plus portal via the standard- supply Wi-Fi and ethernet features giving you a 4.0 kitchen (find out more on [nabookplus.cloud](http://nabookplus.cloud)).



### OWB - ORACLE WASHABLE BOX

A special Teflon oven chamber which can be removed and washed for the next round of cooking, making the cleaning procedure fast and cost-effective.



### OOS - ORACLE ODORLESS SYSTEM

A labyrinth baffle catalyst filter containing platinum particles which help to reduce steam, odours and grease residue during cooking. The Oracle Odorless System does not require any cleaning or routine maintenance work. Its efficiency is always guaranteed.



IPX3



Intertek



Intertek

**Dimensions**

Width	mm 467	inch 18.4
Depth	mm 609	inch 24.0
Height	mm 630	inch 24.8
Packaging width	mm 600	inch 23.6
Packing depth	mm 800	inch 31.5
Packaging height	mm 800	inch 31.5
Net weight	kg 61	lbs 134.5
Gross weight	kg 73	lbs 161.0
Volume	m3 0.18	ft3 6.4
Packing volume	m3 0.38	ft3 13.4
Cooking compartment width	mm 310	inch 12.2
Cooking compartment depth	mm 320	inch 12.6
Cooking chamber height	mm 180	inch 7.1
Support base width	mm 426	inch 16.8
Support base depth	mm 510	inch 20.1
Power plug configuration	CEE 7 / 7 Schuko	
Cable length	m 2	ft 6.56

**Power supply**

Power supply voltage	1N-AC 230 V
Electrical absorption	A 16
Frequency	Hz 50
Total electric power	kW 3,3
Microwave	kW 1
Impingement	kW 3

**OPTIONAL ELECTRIC CONFIGURATION, WITHOUT EXTRA CHARGE - TO BE REQUESTED WHEN ORDERING**

Option code	Connection plug (Plug provided)	Cable length (Provided - mt.)	Power supply voltage	Total electric power		Power output - kW		Country
				kW	A	Impingement	Microwave	
OR53112	A53112	2	1N-AC 230 V - 50 HZ	3	15	3	1	AUS
OR3092	IEC 309	2	1N-AC 230 V - 50 HZ	3,3	16	3	1	
OR1363	BS1363/A	2	1N-AC 230 V - 50 HZ	2,8	13	3	1	
OR1240	-	2	1N-AC 240 V - 60 HZ	3,3	16	3	1	KSA/KO/LATAM
OR1208	-	2	1N-AC 208 V - 60 HZ	3	16	3	1	LATAM

AUS	Australia	EU	Europe	KO	South Korea	KSA	Kingdom of Saudi Arabia	LATAM	Latin America	UK	United Kingdom
-----	-----------	----	--------	----	-------------	-----	-------------------------	-------	---------------	----	----------------

**COOKING MODES**

- COMBI WAVE - MCS (MICROWAVE COOKING SYSTEM) AUTOMATIC COOKING SYSTEM FOR ITALIAN AND INTERNATIONAL RECIPES, INCLUDING THE HISTORY, INGREDIENTS, COOKING ACCESSORIES, PROCEDURE AND AUTOMATIC COOKING PROGRAM. - MANUAL MODE WITH THREE INSTANT START COOKING METHODS: CONVECTION, MICROWAVE OR COMBINED CONVECTION + MICROWAVE.
- HIGH SPEED OVEN - FCS (FAST COOKING SYSTEM) AUTOMATIC COOKING SYSTEM FOR ITALIAN AND INTERNATIONAL RECIPES, INCLUDING THE HISTORY, INGREDIENTS, COOKING ACCESSORIES, METHOD AND AUTOMATIC COOKING PROGRAM. - MANUAL MODE WITH INSTANT START
- PROGRAMMABLE MODE: POSSIBILITY OF PROGRAMMING AND STORING A RECIPE WITH ITS COOKING PROCEDURES IN AUTOMATIC SEQUENCE.

**CONNECTIVITY BETWEEN NABOO AND LAINOX CLOUD (PATENTED) - WI-FI OR ETHERNET**

- AUTOMATIC SOFTWARE UPDATE NOTIFICATION SYSTEM.
- RECIPE CREATION INCLUDING INGREDIENTS WITH PROCEDURE AND PHOTO.
- AUTOMATIC SOFTWARE UPDATES ON MULTIPLE DEVICES SIMULTANEOUSLY.
- POSSIBILITY TO DOWNLOAD RECIPES FROM THE NABOOK PLUS PORTAL BASED ON COUNTRY.
- REMOTE DIAGNOSIS THROUGH THE NABOOK PLUS PORTAL BY THE LAINOX SERVICE CENTER.
- HACCP MONITORING.
- SYNCHRONISATION OF MULTIPLE ORACLE OVENS CONNECTED TO THE SAME ACCOUNT (PATENTED).
- DIRECT ACCESS BY ORACLE TO THE RECIPE DATABASE WITH DOWNLOAD OPTION (PATENTED).
- NABOOK PLUS. YOU CAN ACCESS NABOOK PLUS, THE VIRTUAL COOKING ASSISTANT, THANKS TO ACCESS TO THE CLOUD.
- WI-FI/ETHERNET NABOOK PLUS CONNECTIVITY

**CONTROL MECHANISMS**

- USB CONNECTION TO DOWNLOAD HACCP DATA, UPDATE SOFTWARE AND UPLOAD/DOWNLOAD COOKING RECIPES.
- POSSIBILITY OF CHOOSING THE FAN SPEED IN COMBI WAVE MODE.
- AUTOMATIC FAN SPEED FOR HIGH SPEED OVEN MODE.

**CONSTRUCTION**

- PULL-DOWN DOOR WITH ERGONOMIC HANDLE.
- POSSIBILITY OF CHOOSING THE EXTERNAL COLOUR.
- THE DOOR SLIDES UNDER THE OVEN COOKING SURFACE, ALLOWING THE FOOD TO REMOVED SAFELY WITHOUT THE RISK OF BURNS.
- INTEGRATED CATALYST FILTER FOR OPERATION WITHOUT HOOD.
- PERFECTLY SMOOTH OVEN CHAMBER.
- MADE OF STAINLESS STEEL.

**OPERATION**

- USER INTERFACE WITH A CHOICE OF 29 LANGUAGES.
- AUTOMATIC RESUMPTION OF COOKING IN CASE OF A POWER FAILURE.
- HIGH-DEFINITION 7-INCH CAPACITIVE LCD COLOR SCREEN WITH CHOICE OF "TOUCH SCREEN" FUNCTIONS.
- ORGANISATION OF RECIPES IN FOLDERS WITH PREVIEW, GIVING EACH FOLDER ITS OWN NAME.
- DISPLAY THAT CAN BE CONFIGURED BASED ON THE NEEDS OF THE USER, BRINGING FORWARD THE PROGRAMMES USED MOST.
- ORACLE COACH. VIRTUAL ASSISTANT THAT PROVIDES ADVICE ON USING ORACLE AND INFORMS WHEN MAINTENANCE IS NEEDED.
- THERE ARE NUMEROUS RECIPES AVAILABLE IN ORACLE AND A GROWING NUMBER OF ALTERNATIVE ONES ARE AVAILABLE VIA ACCESS TO THE NABOOK PLUS PORTAL. EACH RECIPE HAS BEEN TESTED TO GUARANTEE BEST RESULTS.
- RAPID COOLING OF THE COOKING CHAMBER WITH OPEN DOOR.
- POSSIBILITY OF PREHEATING THE COOKING CHAMBER UP TO 300°C.
- AUTOMATIC COOKING WITH "ONE TOUCH" START.

**SAFETY FEATURES**

- MAX 65°C EXTERNAL TEMPERATURE ON THE DOOR PANEL.
- SELF-DIAGNOSIS WITH SMART ERROR VIEWING.
- DOOR OPEN/CLOSED ELECTRONIC SENSOR.
- COMPLIANT WITH THE IEC60335-1, IEC60335-2-90 AND EMC INTERNATIONAL STANDARDS.

**CLEANING AND MAINTENANCE**

- EASY EXTERNAL CLEANING THANKS TO THE PERFECTLY SMOOTH SURFACES AND IPX3 PROTECTION RATING AGAINST WATER SPRAY.
- OWB, ORACLE WASHABLE BOX, SPECIAL REMOVABLE AND WASHABLE OVEN BOX.

**INSTALLATION & ENVIRONMENT**

- QUALITY ISO 9001 / SAFETY ISO 45001 / ENVIRONMENTAL ISO 14001 CERTIFICATION.
- PRODUCT RECYCLING RATE 90%.
- 100% RECYCLABLE PACKAGING.
- INSTALLATION & ENVIRONMENT

**STANDARD EQUIPMENT**

- WI-FI CONNECTION
- USB CONNECTION
- PLUG - ONLY FOR 50 HZ
- REMOVABLE AND WASHABLE INNER DOOR PROTECTION
- ORACLE WASHABLE BOX. SPECIAL REMOVABLE, NON-STICK, WASHABLE TEFLON OVEN BOX.
- ALUMINIUM PEEL
- COOKING PLATE
- ETHERNET CONNECTION
- POWER CABLE - 2 MT.

**OPTIONAL TO BE REQUESTED WHEN ORDERING**

- OR53112:** OPTIONAL ELECTRIC CONFIGURATION, WITHOUT EXTRA CHARGE. 1N-AC 230 V - 50 HZ. 1N-AC 240 V - 50 HZ. PLUG A53112
- OR3092:** OPTIONAL ELECTRIC CONFIGURATION, WITHOUT EXTRA CHARGE. 1N-AC 230 V - 50 HZ. PLUG IEC 309
- OR1363:** OPTIONAL ELECTRIC CONFIGURATION, WITHOUT EXTRA CHARGE. 1N-AC 230 V - 50 HZ. 1N-AC 240 V - 50 HZ. PLUG BS1363/A
- OR1240:** OPTIONAL ELECTRIC CONFIGURATION, WITHOUT EXTRA CHARGE. 1N-AC 240 V - 60 HZ.
- OR1208:** OPTIONAL ELECTRIC CONFIGURATION, WITHOUT EXTRA CHARGE. 1N-AC 208 V - 60 HZ.
- MPACK:** MULTIPACK PACKAGING - 6 PCS MIXED IN A SINGLE PACKAGE - 1200 X 800 X 2170 H - 415 KG - 2.08 M3

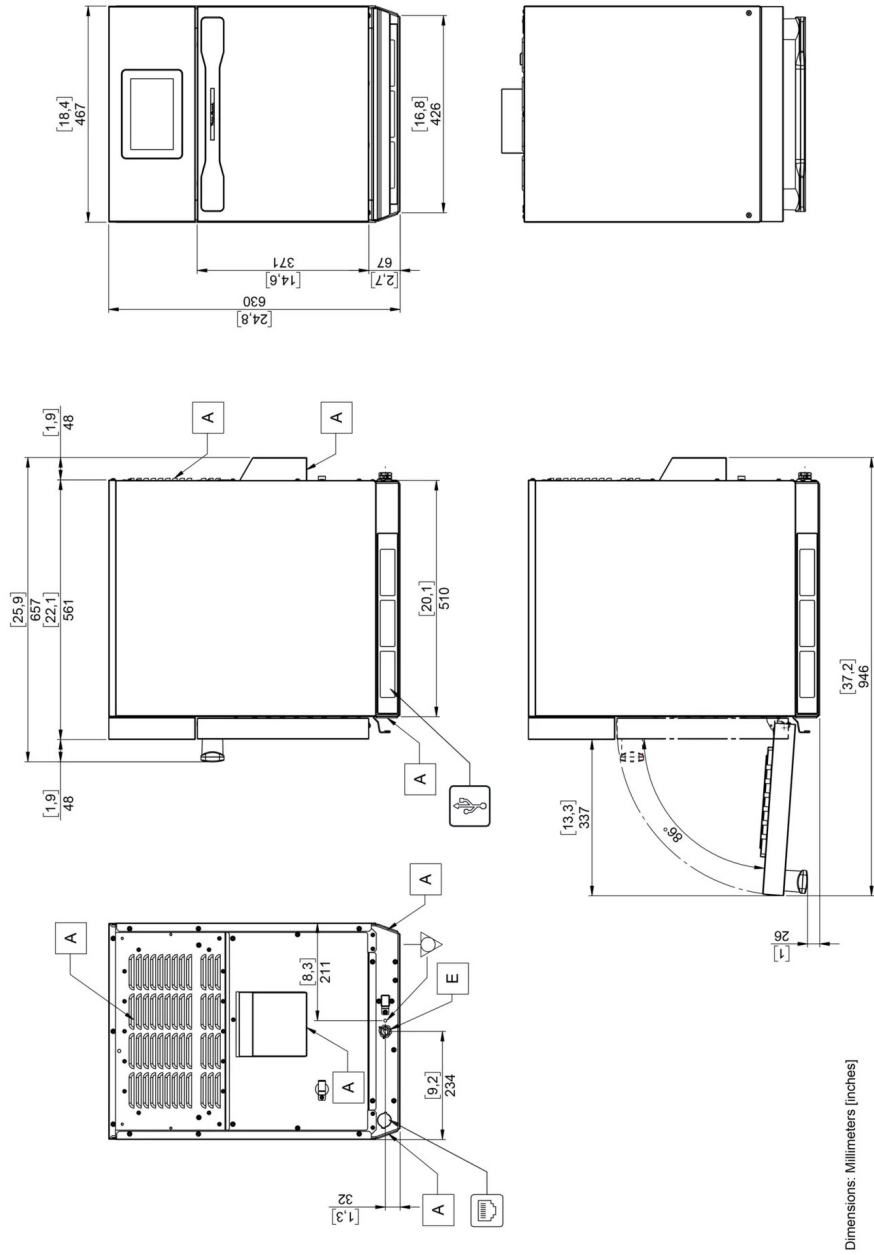

Dimensions: Millimeters [inches]

A	Technical compartment cooling air intake
E	Electric power supply cable inlet
	Ethernet connection
	USB connection

The data reported in this document is to be considered non-binding. The company reserves the right to make changes at any time, without prior notice



Lainox Ali Group S.r.l.  
Via Schiaparelli 15  
Z.I. S. Giacomo di Veglia  
31029 Vittorio Veneto (TV) - Italy

Tel +39 0438 91110  
Fax +39 0438 912300  
lainox@lainox.com  
www.lainox.com

